

Subminiature Sensor with Inline Amplifier Offers Greater Mounting Flexibility

- Subminiature, shielded sensing head (3-mm or 8-mm dia.) allows the Sensor to be flush-mounted in metal
- Longer sensing distance: 2.5 mm with 8-mm dia. sensing head
- Side-by-side mounting of cable amplifier units possible
- Robotic cable on DC two-wire models withstands repeated flexing on robots and reciprocating machinery
- Simple connection to PLCs



Ordering Information

■ DC 2-WIRE MODELS

Type	Size	Sensing distance	Output configuration	Part number
	3 mm dia.	0.8 mm (0.03 in)	NO	E2EC-CR8D1
			NC	E2EC-CR8D2
	5.4 mm dia.	1.5 mm (0.06 in)	NO	E2EC-C1R5D1
			NC	E2EC-C1R5D2
	8 mm dia.	3 mm (0.12 in)	NO	E2EC-C3D1
			NC	E2EC-C3D2
	M12	4 mm (0.16 in)	NO	E2EC-X4D1
			NC	E2EC-X4D2

Note: Models different in frequency are available with the E2EC-□□□□5 models (e.g., E2EC-CR8D15).

■ DC 3-WIRE MODELS

Type	Size	Sensing distance	Output configuration	Part number	
				NPN	PNP
	3 mm dia.	0.5 mm (0.02 in)	NO	E2EC-CR5C1	E2EC-CR5B1
	8 mm dia.	2.5 mm (0.10 in)	NO	E2EC-C2R5C1	E2EC-C2R5B1

Specifications

■ RATINGS/CHARACTERISTICS

Description		2-wire DC models				3-wire DC models (NPN)		3-wire DC models (PNP)	
Part number		E2EC-CR8D□	E2EC-C1R5D□	E2EC-C3D□	E2EC-X4D□	E2EC-CR5C1	E2EC-C2R5C1	E2EC-CR5B1	E2EC-C2R5B1
Body	Size	3 mm	5.4 mm	8 mm	3 mm	3 mm	8 mm	3 mm	8 mm
	Type	Inductive							
Supply voltage (operating voltage range)		12 to 24 VDC (10 to 30 VDC), ripple (p-p): 10% max.				5 to 24 VDC (4.75 to 30 VDC), ripple (P-P): 10% max.			
Current consumption		---				10 mA max.			
Leakage current		0.8 mA max.				---			
Sensing object		Magnetic metals (Refer to <i>Engineering Data</i> for non-magnetic metals.)							
Sensing distance		0.8 mm ±15%	1.5 mm ±10%	3 mm ±10%	4 mm ±10%	0.5 mm ±15%	2.5 mm ±10%	0.5 mm ±15%	2.5 mm ±10%
Sensing distance (with standard sensing object)		0 to 0.56 mm (0.02 in) (iron: 5 x 5 x 1 mm)	0 to 1.05 mm (0.04 in) (iron: 5 x 5 x 1 mm)	0 to 2.1 mm (0.08 in) (iron: 8 x 8 x 1 mm)	0 to 2.8 mm (0.11 in) (iron: 12 x 12 x 1 mm)	0 to 0.3 mm (0.011 in) (iron: 5 x 5 x 1 mm)	0 to 1.7 mm (0.067 in) (iron: 8 x 8 x 1 mm)	0 to 0.3 mm (0.011 in) (iron: 5 x 5 x 1 mm)	0 to 1.7 mm (0.067 in) (iron: 8 x 8 x 1 mm)
Differential travel		10% max. of sensing distance							
Control output	Type	DC 2-wire				NPN-NO open collector		PNP-NO open collector	
	Max. load	5 to 100 mA				100 mA max. at 30 VDC			
Residual voltage		3.0 V max. (under load current of 100 mA with cable length of 2 m)				1.0 V max. (under load current of 100 mA with cable length of 2 m)			
Operation (with sensing object approaching)		D1 models: Load operates. D2 models: Load is reset.				Load operates.			
Temperature influence		±20% max. of sensing distance at 23°C (73.4°F) in temperature range of -25°C and 70°C (-13°F to 158°F)							
Voltage influence		±2.5% max. of sensing distance in rated voltage when operated within ±15% of the rated supply voltage				±5% max. of sensing distance in rated voltage range of 4.75 to 30 V			
Response frequency (see note)		1.5 kHz		1 kHz					
Circuit protection		Surge absorber and load short-circuit protection				Surge absorber			
Indicator		D1 models: Operation indicator (red LED), operation set indicator (green LED) D2 models: Operation indicator (red LED)				Detection indicator (red LED)			
Head material	Case	Brass							
	Sensing surface	ABS resin							
Weight		Approx. 45 g (1.59 oz)							
Enclosure rating		IEC IP67				IEC IP64			
Ambient temperature		Operating: -25°C to 70°C (-13°F to 158°F) with no icing							
Ambient humidity		Operating: 35% to 95%							
Vibration resistance		Malfunction: 10 to 55 Hz, 1.5-mm double amplitude for 2 hrs each in X, Y, and Z directions							
Shock resistance		Malfunction: 1,000 m/s ² (3,280 ft/sec ²) (approx. 100G) for 10 times each in X, Y, and Z directions				Malfunction: 500 m/s ² (1,640 ft/sec ²) (approx. 50G) for 10 times each in X, Y, and Z directions			
Insulation resistance		50 MΩ (at 500 VDC) between current carry parts and case							
Dielectric strength		1,000 VAC (50/60 Hz) for 1 min between current carry parts and case				500 VAC (50/60 Hz) for 1 min between current carry parts and case			

Note: Response frequencies are mean values measured with standard sensing objects, each separated from one another with a distance that is double the size of the sensing object and located at a distance that is half the sensing distance.

Operation

OUTPUT CIRCUITS

Colors in parentheses are previous ones.

DC 2-WIRE MODELS

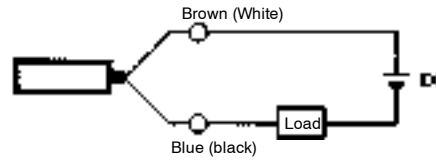
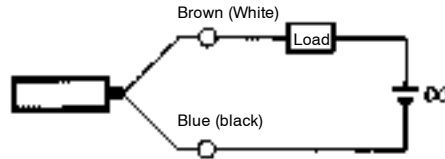
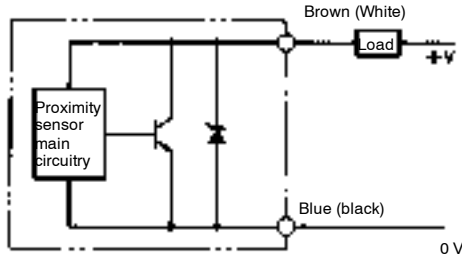

Note: As shown in the above circuit diagrams, the load can be connected in two ways.

DC 3-WIRE MODELS

PNP

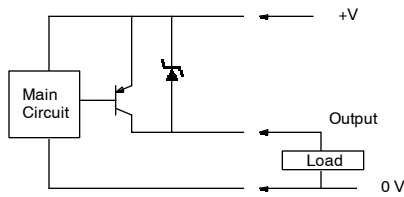

NPN

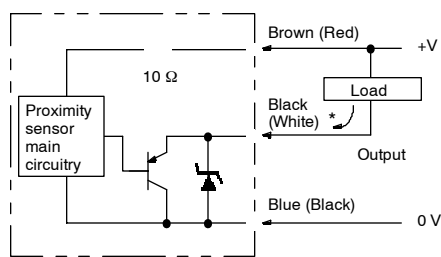

Note: 100 mA max. (load current)

OPERATING CHARTS

DC 2-wire Models

NO Model

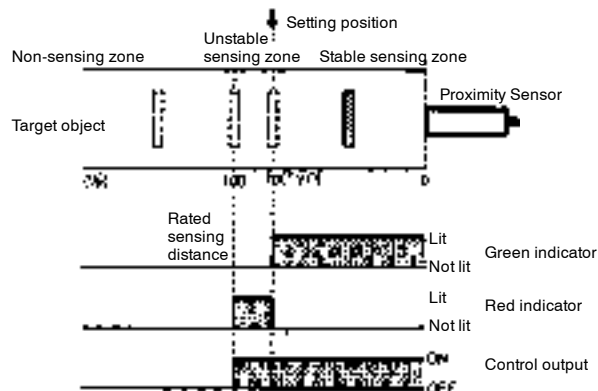

NC Model

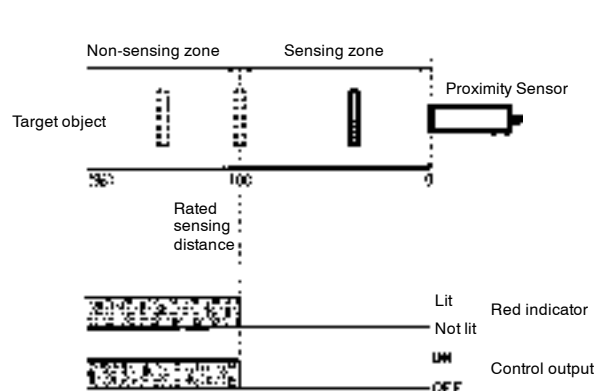

DC 3-wire Models

Sensing object	Yes	<input type="checkbox"/>
	No	<input type="checkbox"/>
Output transistor (Load)	Operates	<input type="checkbox"/>
	Releases	<input type="checkbox"/>
Detection indicator (LED)	ON	<input type="checkbox"/>
	OFF	<input type="checkbox"/>

Engineering Data

OPERATING RANGE (TYPICAL)

E2EC-CR8D1

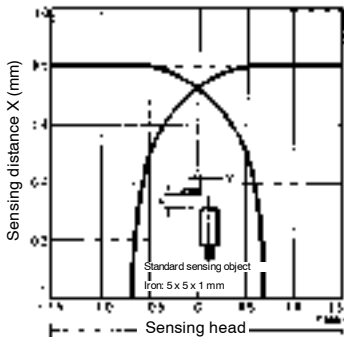

E2EC-C1R5D1

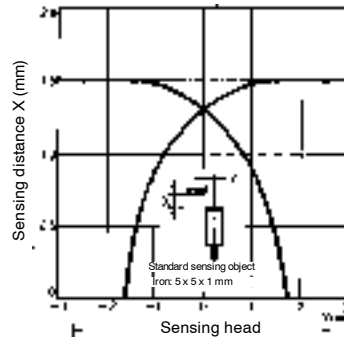

E2EC-C3D1

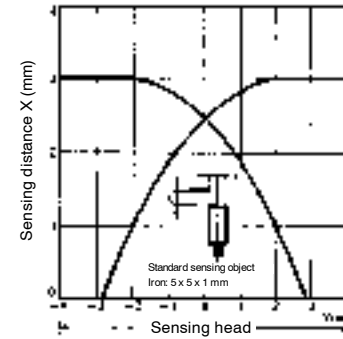

E2EC-X4D1

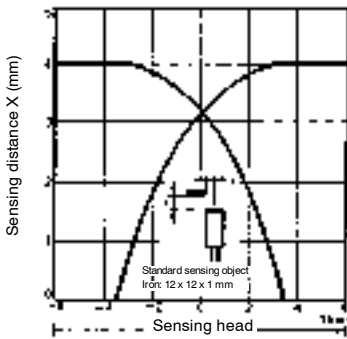

E2EC-CR5C1

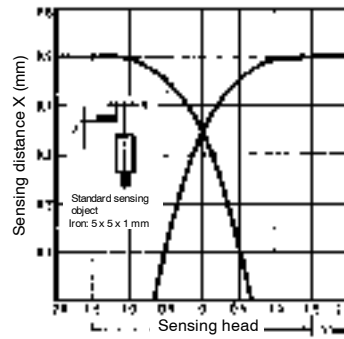

E2EC-C2R5C1

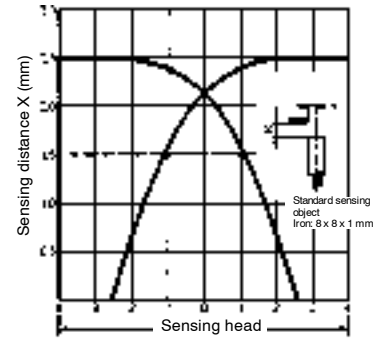

RESIDUAL OUTPUT VOLTAGE (TYPICAL)

DC 2-wire Models

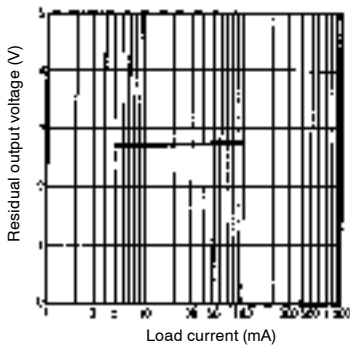

LEAKAGE CURRENT (TYPICAL)

DC 2-wire Models

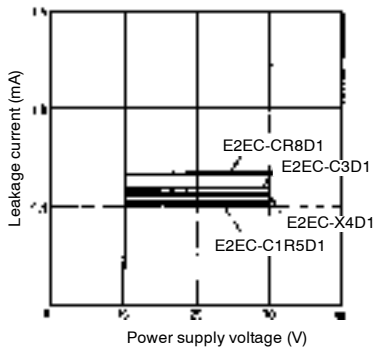

■ SENSING DISTANCE VS. SENSING OBJECT (TYPICAL)

E2EC-CR8D1

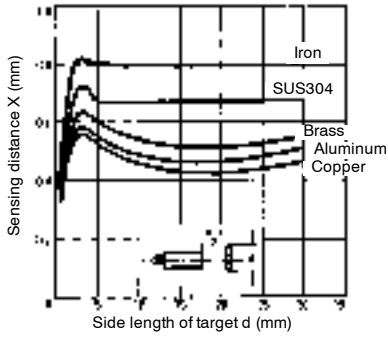

E2EC-C1R5D1

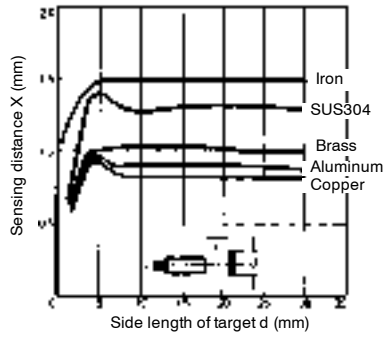

E2EC-C3D1

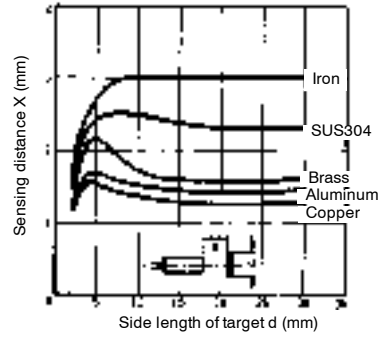

E2EC-X4D1

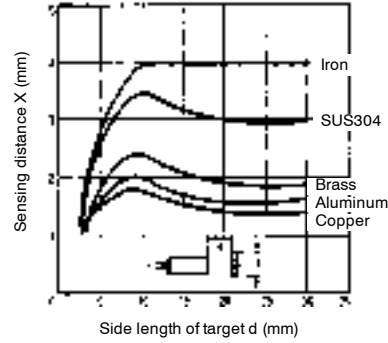

E2EC-CR5C1

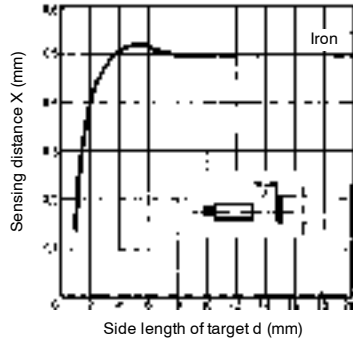

E2EC-C2R5C1

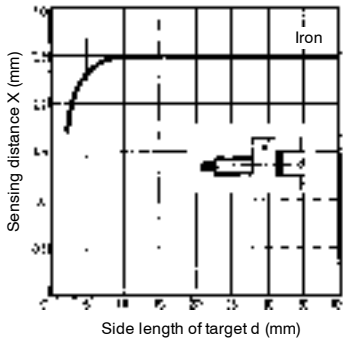

Dimensions

Unit: mm (inch)

■ DC 2-WIRE SENSORS

E2EC-CR8D□

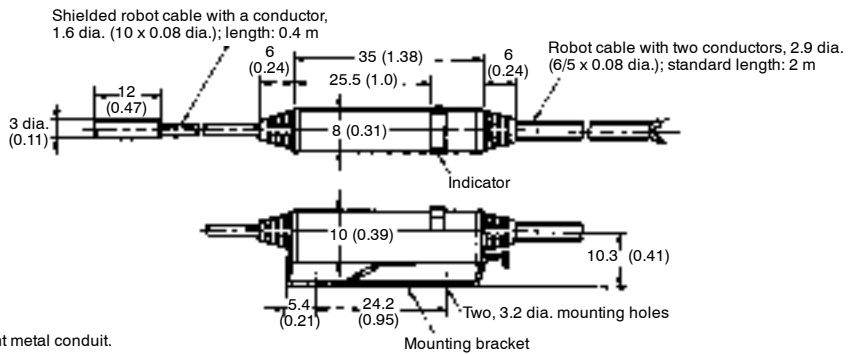

The cable can be extended up to 200 m in an independent metal conduit.

E2EC-C1R5D

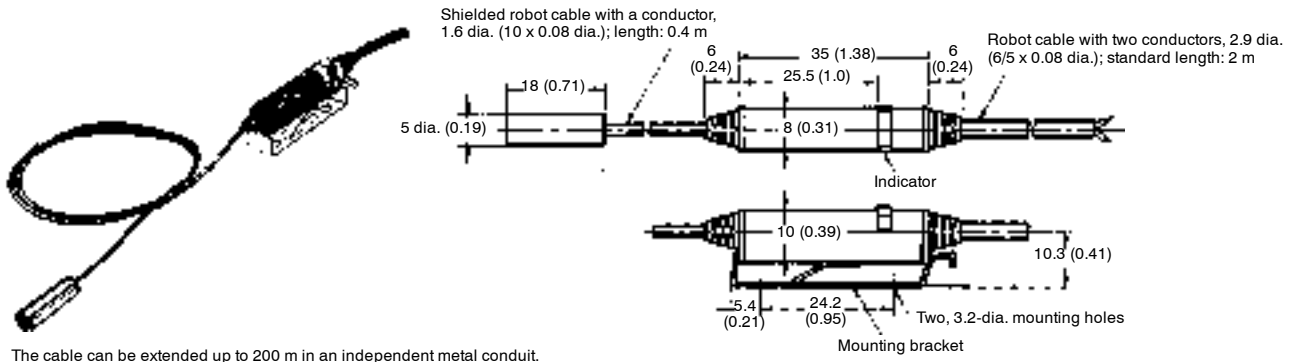

The cable can be extended up to 200 m in an independent metal conduit.

E2EC-C3D

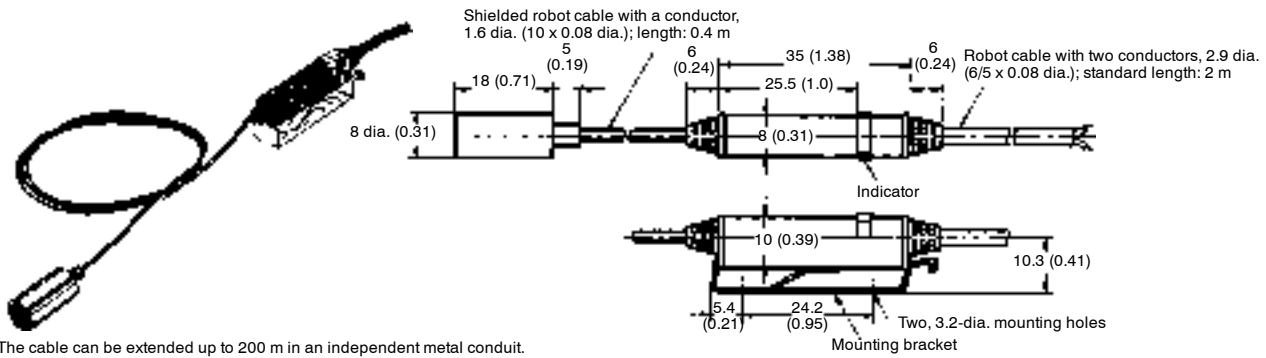

The cable can be extended up to 200 m in an independent metal conduit.

E2EC-X4D

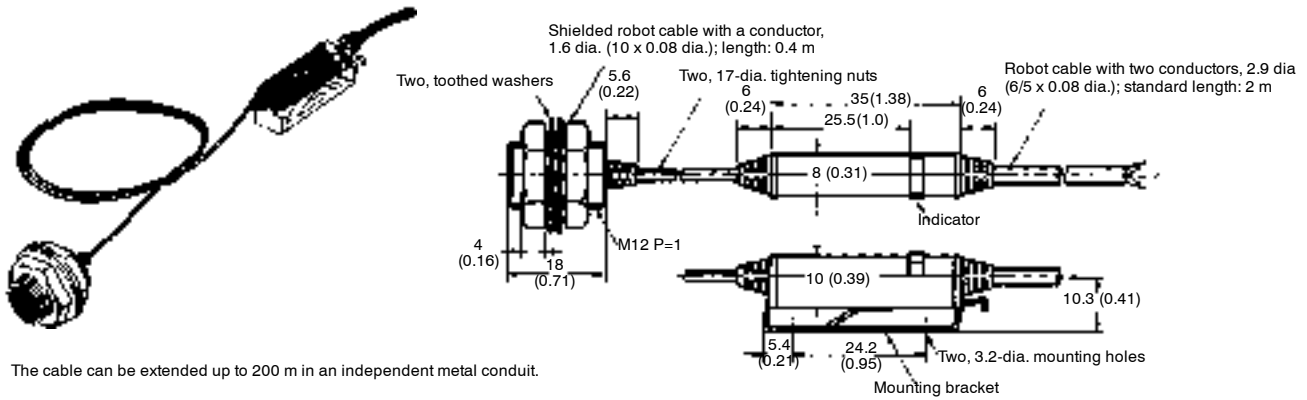

The cable can be extended up to 200 m in an independent metal conduit.

■ DC 3-WIRE SENSORS

E2EC-CR5C1

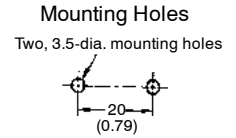
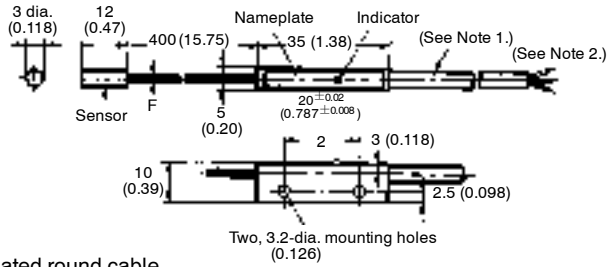

- Note: 1. Oil-and vibration-resistant, vinyl-insulated round cable with three conductors, 4 dia. (0.5 mm x 3); standard length: 2 m
 2. The cable can be extended up to 200 m in an independent metal conduit.

E2EC-C2R5C1

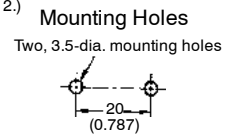
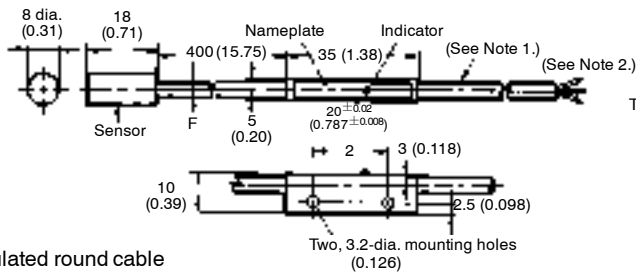

- Note: 1. Oil-and vibration-resistant, vinyl-insulated round cable with three conductors, 4 dia. (0.5 mm x 3); standard length: 2 m
 2. The cable can be extended up to 200 m in an independent metal conduit.

■ MOUNTING HOLE

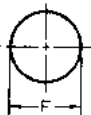

This table refers to "F" in above dimensions drawing

Part number	F (mm)
E2EC-CR8D□	3.3 ^{+0.3} / ₀ mm (.13 ^{+0.01} / ₀ in) dia
E2EC-C1R5D□	5.7 ^{+0.3} / ₀ mm (.24 ^{+0.01} / ₀ in) dia
E2EC-C3D□	8.5 ^{+0.5} / ₀ mm (.33 ^{+0.02} / ₀ in) dia
E2EC-X4D□	12.5 ^{+0.5} / ₀ mm (.49 ^{+0.02} / ₀ in) dia
E2EC-CR5□1	3.3 ^{+0.3} / ₀ mm (.13 ^{+0.01} / ₀ in) dia
E2EC-C2R5□1	8.5 ^{+0.5} / ₀ mm (.33 ^{+0.02} / ₀ in) dia

■ AMPLIFIER MOUNTING BRACKET

This table refers to "F" in above

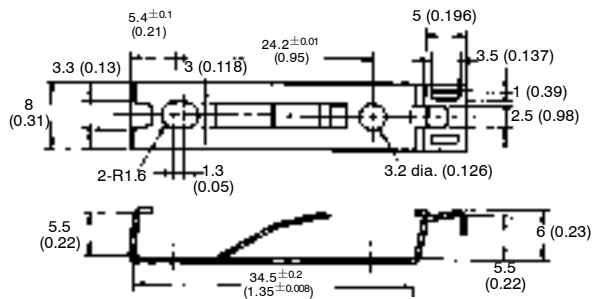
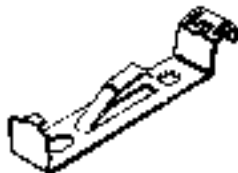

Precautions

■ MOUNTING

Refer to the following table for the torque and tightening ranges applied to mount unthreaded E2EC-C models.

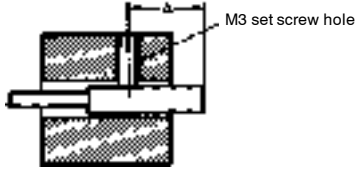

Permissible Tightening Range and Torque

Model	Tightening range A	Set-screw tightening torque
E2EC-CR8D	6 to 10 mm (0.24 to 0.39 in)	5 kgf • cm {0.49 N • m} (0.36 ft • lbf)
E2EC-C1R5D	8 to 16 mm (0.31 to 0.62 in)	5 kgf • cm {0.49 N • m} (0.36 ft • lbf)
E2EC-C3D	8 to 16 mm (0.31 to 0.62 in)	10 kgf • cm {0.98 N • m} (0.72 ft • lbf)
E2EC-CR5□1	6 to 10 mm (0.24 to 0.39 in)	4 kgf • cm {0.39 N • m} (0.29 ft • lbf)
E2EC-C2R5□1	8 to 16 mm (0.31 to 0.62 in)	

The tightening torque applied to the E2EC-X4D (i.e., models with column screws) must be 120 kgf • cm (12 N • m) max.



■ EFFECTS OF SURROUNDING METAL

When mounting the E2EC within a metal panel, ensure that the clearances given in the following table are maintained.

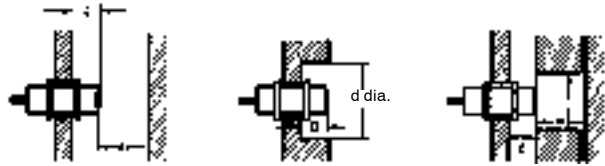

Mounting Conditions

Item	E2EC-CR8D	E2EC-C1R5D	E2EC-C3D	E2EC-X4D	E2EC-CR5□1	E2EC-C2R5□1
ℓ	0	0	0	0	0	0
d	3 (0.12)	5.4 (0.25)	8 (0.32)	12 (0.47)	3 (0.12)	8 (0.32)
D	0	0	0	0	0	0
m	2.4 (0.94)	4.5 (0.17)	9 (0.35)	12 (0.47)	1.5 (0.06)	10 (0.39)
n	6 (0.24)	10.8 (0.43)	16 (0.63)	24 (0.94)	5 (0.20)	21 (0.83)

■ MUTUAL INTERFERENCE

When mounting more than one E2EC face to face or side by side, ensure that the minimum distances given in the following table are maintained.



Item	E2EC-CR8D	E2EC-C1R5D	E2EC-C3D	E2EC-X4D	E2EC-CR5□1	E2EC-C2R5□1
A	8 [4] 0.32 (0.16)	15 [8] 0.59 (0.32)	30 [15] 1.18 (0.59)	40 [20] 1.57 (0.78)	20 [10] 0.78 (0.39)	40 [20] 1.57 (0.78)
B	6 [3] 0.24 (0.12)	10.8 [5.4] 0.43 (0.21)	16 [8] 0.63 (0.32)	24 [12] 0.94 (0.47)	15 [3] 0.59 (0.12)	25 [15] 0.98 (0.59)

Note: Figures in brackets are for Sensors operating at different frequencies.

■ MOUNTING BRACKET FOR DC 2-WIRE MODELS

Mounting

1. Insert the amplifier into the trapezoidal end (i.e., the fixing side) of the mounting bracket.



2. Press the other end of the amplifier onto the bracket.

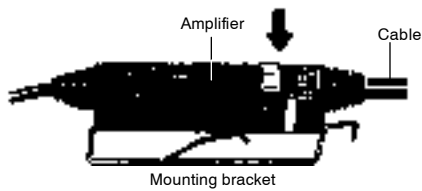

Removal

1. Lightly press the hook of the mounting bracket with a flat-blade screwdriver.



2. The amplifier will automatically spring loose from the mounting bracket.



NOTE: DIMENSIONS SHOWN ARE IN MILLIMETERS. To convert millimeters to inches divide by 25.4.

OMRON®

OMRON ELECTRONICS LLC

One East Commerce Drive
Schaumburg, IL 60173

1-800-55-OMRON

OMRON ON-LINE

Global - <http://www.omron.com>
USA - <http://www.omron.com/oei>
Canada - <http://www.omron.com/oci>

OMRON CANADA, INC.

885 Milner Avenue
Scarborough, Ontario M1B 5V8

416-286-6465